



PROSIMPLUS APPLICATION EXAMPLE

LPG RECOVERY UNIT

USING PROPANE REFRIGERATION

INTEREST OF THIS EXAMPLE

This example shows a process of LPG recovery in a gas with a propane refrigeration loop. This process is particularly inter-connected and includes several recycle loops.

Additionally, beside the implementation of the absorber module (acting as the deethanizer) and of the refrigeration loop, this process uses the plate fin heat exchanger module of ProSimPlus, a particularly complex unit operation. This type of exchangers can include as many as 10 different streams which makes the modeling and the associated calculation particularly complex.

ACCESS	<input checked="" type="checkbox"/> Free-Internet	<input type="checkbox"/> Restricted to ProSim clients	<input type="checkbox"/> Restricted	<input type="checkbox"/> Confidential
--------	---	---	-------------------------------------	---------------------------------------

CORRESPONDING PROSIMPLUS FILE	PSPS_E06_FR – LPG Recovery.pmp3
-------------------------------	---

Reader is reminded that this use case is only an example and should not be used for other purposes. Although this example is based on actual case it may not be considered as typical nor are the data used always the most accurate available. ProSim shall have no responsibility or liability for damages arising out of or related to the use of the results of calculations based on this example.

TABLE OF CONTENTS

1. PROCESS MODELING	3
1.1. Process description	3
1.2. Heat exchanger description	3
1.3. Process flowsheet	6
1.4. Specifications	6
1.5. Components	6
1.6. Thermodynamic model	7
1.7. Operating conditions	7
1.8. "Hints and Tips"	10
2. RESULTS	11
2.1. Comments on results	11
2.2. Mass and energy balances	11
2.3. Profile of temperature of reference sheet in the E101 exchanger	12
2.4. Column C101 composition profiles	12
3. REFERENCES	14

1. PROCESS MODELING

1.1. Process description

The objective of this process is to recover liquefied petroleum gases (LPG) with a fixed mass fraction of methane, from a gas mixture. The main LPG components are hydrocarbons (mainly in the C3-C4 range), propane and butane.

The initial gas mixture is sent in a two-phase separator (S101) in order to eliminate the heaviest compounds which are sent to the distillation column (C101). The others leave at the top of the vessel and are cooled in the brazed plate fin heat exchanger (E101). They are then forwarded in another two-phase separator (S102) to separate heavy and lights. The two output streams (heavy and light) are sent back in the plate-fin heat exchanger as cold streams.

Once treated, the gas is mainly composed of methane and ethane and flows out of the exchanger (stream C04out). The gas, not entirely liquefied, is sent to a deethanizer column (C101), like the bottom stream of the first two-phase separator. This column is set to recover at the bottom a liquid having the specified mass fraction of methane.

The main cold streams of the plate fin heat exchanger are the two propane streams (C05out and C06out). On the outlet side of the plate fin heat exchanger they are mixed and sent to a compressor (K101) which increases their pressure and temperature. The heat generated is recovered in an exchanger (E102). Propane then flows in an expansion valve (v101) in order to decrease its pressure. A liquid-gas mixture is formed and sent in a separator (S104). Liquid propane is returned in the plate-fin heat exchanger (streams C05in and C06in). The gas propane (stream C12) is mixed with hot streams of propane leaving the brazed plate fin heat exchanger (E101).

Propane circulates in a closed loop within the system where it acts as refrigerant.

The example is extracted from [1].

1.2. Heat exchanger description

This process implements a plate-fin heat exchanger (E101). Only one of these exchangers can contain more than ten different streams. Thanks to its low cost of production and its high performances (they are generally made of brazed aluminum), it is increasingly used in cryogenic processes. The model implemented in ProSimPlus is a detailed model which takes account all the complexity of the geometry of this type of exchangers. The single assumption made is of a common wall temperature off stacking (known as TPC assumption).

Another ProSim software, ProSec, makes it possible to bypass this assumption for an even more accurate calculation.

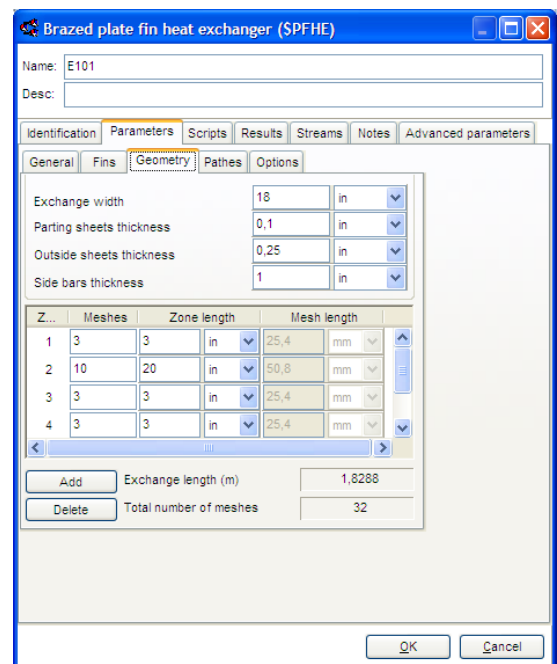

The heat exchanger can be summarized in the figure below:

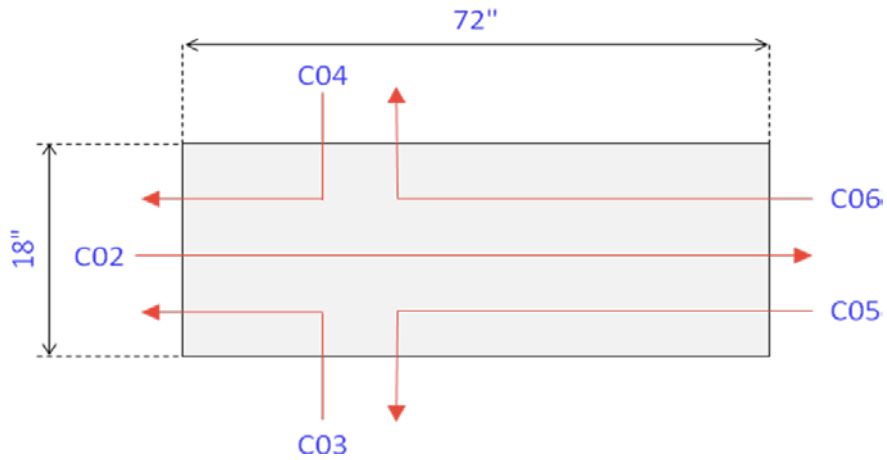

The exchanger is composed of three references paths, shared by the hot and cold streams. The main stream (C02) flows throughout the heat exchanger, the secondary streams are withdrawn (C05, C06) or fed (C03, C04) on the side of the unit.

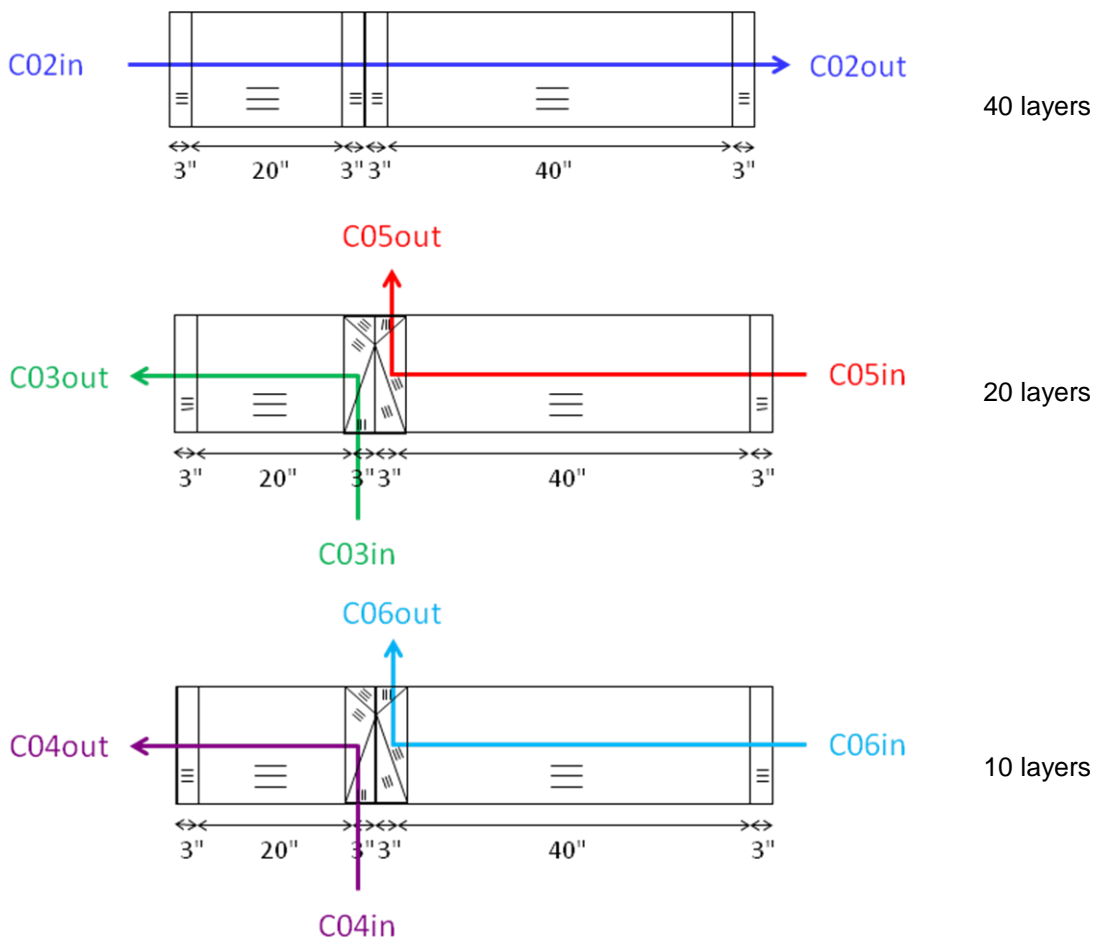

The figures below presents the fins used for the several flow paths in the heat exchanger as well as their topology (exchange, distribution and dead zones). Only one fin is used in this example (Fin #2873 from Fives Cryo (formerly Nordon Cryogénie)):

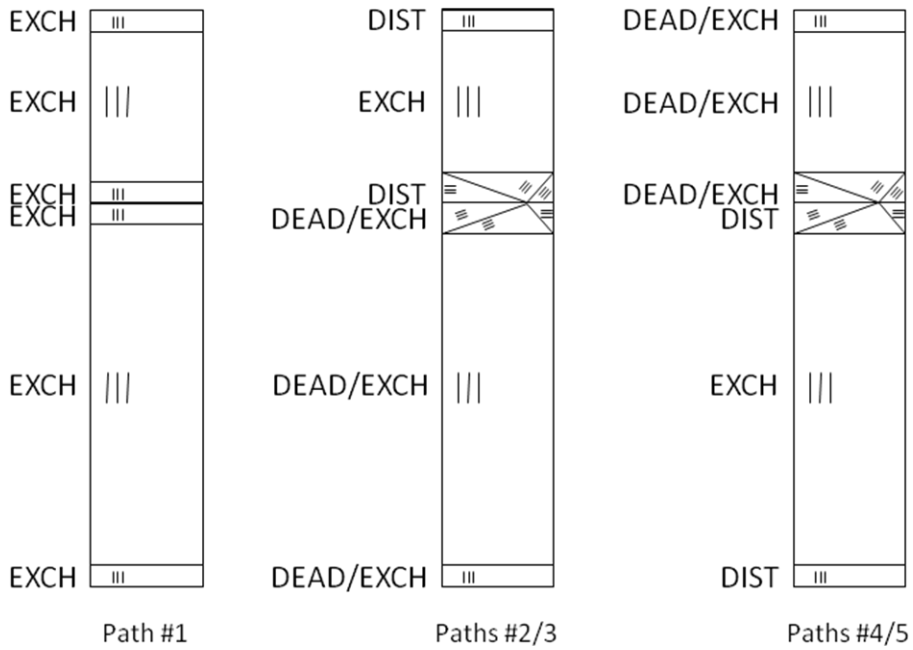
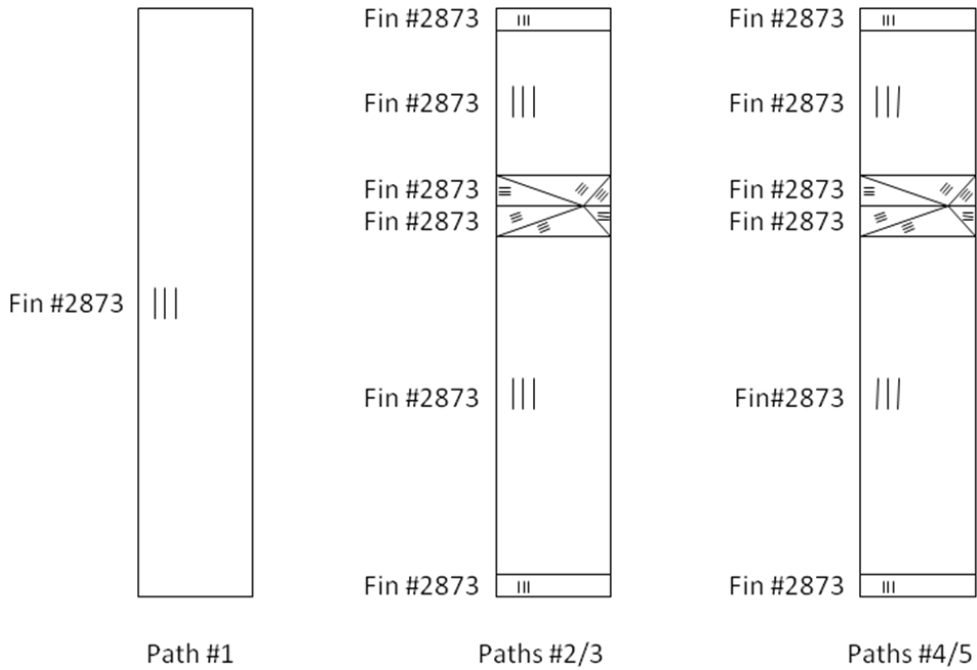

1.3. Process flowsheet

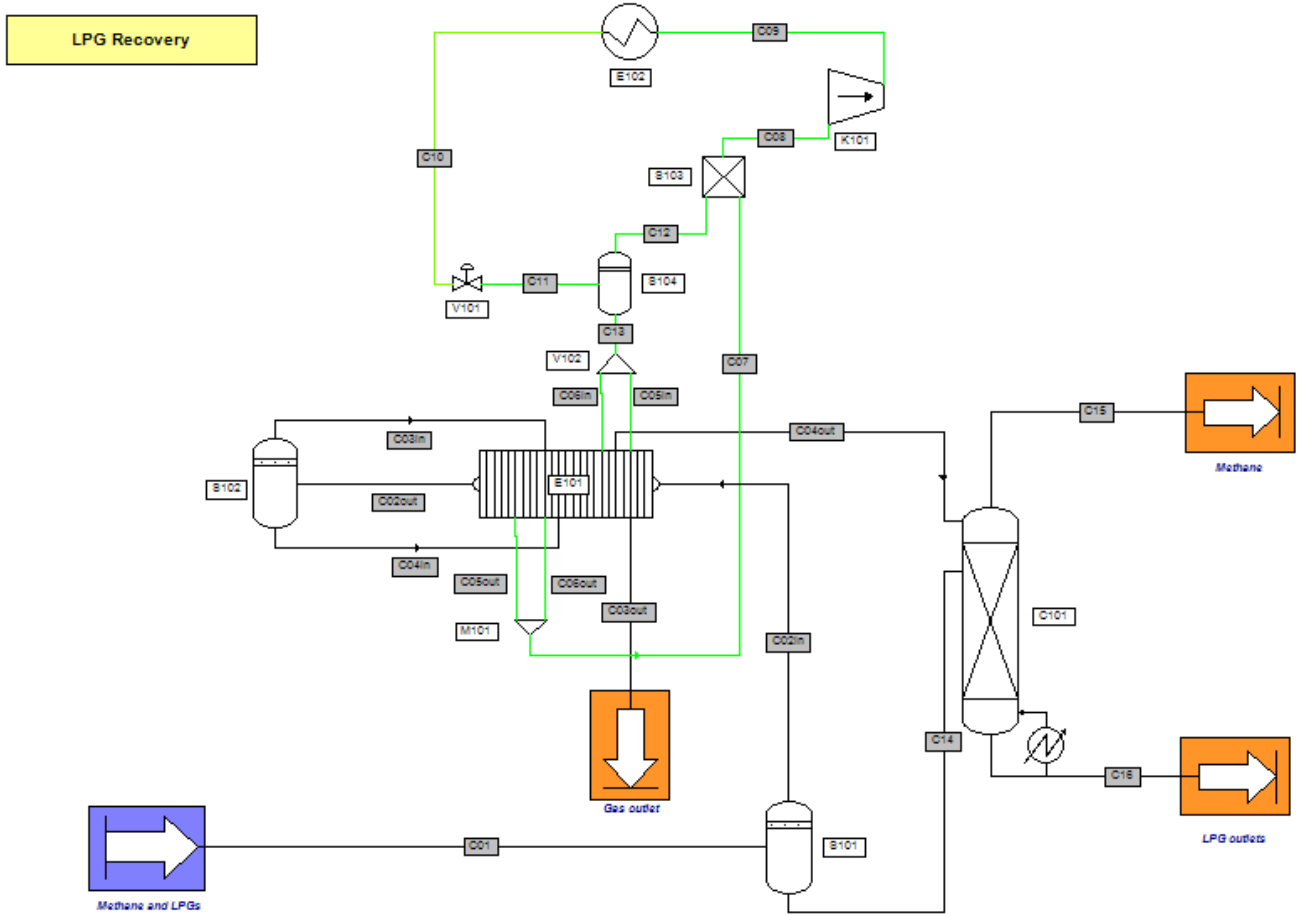

LPG recovery unit process flowsheet

1.4. Specifications

The constraint of this process is to recover LPG with a mass fraction of methane equal to 0.05 in the bottom liquid product of the deethanizer. This constraint is set in the column (C101) configuration window (“Objectives / Constraints” tab).

1.5. Components

The components involved in the simulation are extracted from the standard data base provided with ProSimPlus. These components are defined in the table hereafter:

- | | |
|-------------|--------------|
| ❖ Nitrogen | ❖ n-Butane |
| ❖ Methane | ❖ Isopentane |
| ❖ Ethane | ❖ n-Pentane |
| ❖ Propane | ❖ n-Hexane |
| ❖ Isobutane | ❖ n-Heptane |

1.6. Thermodynamic model

The thermodynamic model is based on an equation of state approach. The chosen equation of state is the Peng Robinson (PR) [2] equation with binary interaction parameters extracted from the ProSimPlus database.

1.7. Operating conditions

✓ Process feed

Temperature (F)	115
Pressure (psi)	833
Total mass throughput (lb/h)	26297.8
<i>Mass fractions</i>	
Nitrogen	0.000228
Methane	0.591275
Ethane	0.098868
Propane	0.141162
Isobutane	0.040548
n-Butane	0.044816
Isopentane	0.020351
n-Pentane	0.014024
n-Hexane	0.016791
n-Heptane	0.031937

✓ Heat Exchanger E101

<i>Operating parameters</i>	<i>Value</i>
Type of exchanger	Plate fin heat exchanger
Number of exchanger blocks	1
Number of paths	5
Total passage numbers	70
Design material	Aluminum
Position of the exchanger	Horizontal
Fins	Fives Cryo 2873
Porosity (%)	2.5
Heat transfer coefficient (W/m ² /K)	Constant = 1000
Fouling coefficient (W/m ² /K)	0

<i>Geometry</i>	
Exchange width (in)	18
Parting sheets thickness (in)	0.1
Outside sheets thickness (in)	0.25
Side bars thickness (in)	1
Paths description	see § 1.2

✓ Separator S101

<i>Operating parameters</i>	<i>Value</i>
Type of separator	Vapor-Liquid separator
Temperature (F)	113
Pressure (psi)	inlet pressure

✓ Separator S102

<i>Operating parameters</i>	<i>Value</i>
Type of separator	Vapor-Liquid separator
Temperature (F)	-5
Pressure (psi)	inlet pressure

✓ Separator S103

<i>Operating parameters</i>	<i>Value</i>
Type of separator	Vapor-Liquid separator
Temperature (F)	Temperature resulting of the adiabatic mixing of the feeds
Pressure (psi)	Lowest pressure of the feeds
Pressure drop (psi)	9

✓ Compressor K101

<i>Operating parameters</i>	<i>Value</i>
Exhaust pressure (psi)	258
Isentropic efficiency	0.72
Mechanical efficiency	1
Electrical efficiency	1

✓ Exchanger E102

<i>Operating parameters</i>	<i>Value</i>
Type of exchanger	Cooler/Heater
Output temperature (F)	-7

✓ Valve V101

<i>Operating parameters</i>	<i>Value</i>
Type of valve	Expansion valve
Pressure (psi)	31

✓ Valve V102

<i>Operating parameters</i>	<i>Value</i>
Type of valve	Stream splitter
Splitting rate	0.5

✓ Column C101

<i>Operating parameters</i>	<i>Value</i>
Type of column	Two-phase absorber with reboiler
Number of theoretical stages	30
Feed stage	10
Vapor flowrate at the top of column (lb/h)	1200

Additional column specification:

<i>Specification</i>	<i>Type of product</i>	<i>Component</i>	<i>Value</i>	<i>Phase</i>	<i>Type</i>	<i>Action</i>
1: Purity	Bottom liquid product	Methane	0.05	Liq.	wt.	Vapor distillate flowrate

1.8. "Hints and Tips"

The propane refrigeration loop can operate with an unspecified circulating propane flowrate, as it is a closed loop (the flow among C07 and the flow of C13 exit are equal).

In order to set the flowrate of propane circulating in the loop it is necessary to initialize one of the streams of the loop, here the stream C10 was selected.

In order to modify the refrigeration efficiency it will be necessary to modify this initialization of the flowrate of C10.

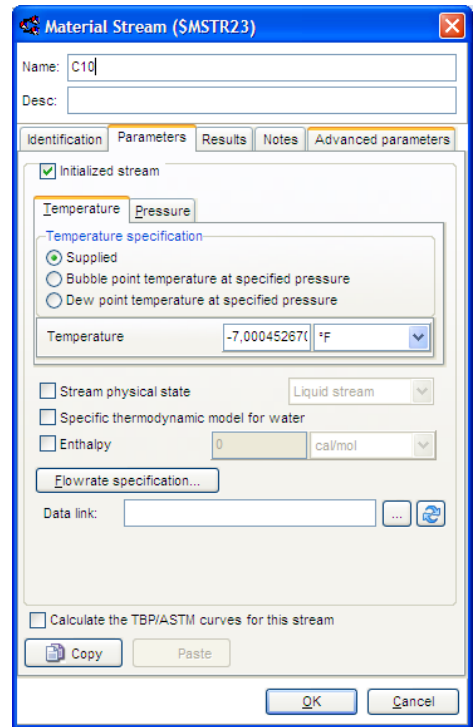

2. RESULTS

2.1. Comments on results

The calculation sequence (order of calculation of the unit operations) is generated automatically. The streams C10 (see § 1.8) and C02out are initialized.

2.2. Mass and energy balances

This document presents only the most relevant stream results. In ProSimPlus, mass and energy balances are provided for every stream. Results are also available at the unit operation level (result tab in the configuration window).

Streams		C01	C02in	C03out	C04out	C07	C15	C16
From		Process feed	S101	E101	E101	M101	C101	C101
To		S101	E101	Gas Output	C101	S103	C1-C2 Output	LPG Output
Partial flowrate		lb/h	lb/h	lb/h	lb/h	lb/h	lb/h	lb/h
NITROGEN		5,9959	5,9874	5,7972	0,1902	0,0000	0,1954	0,0033
METHANE		15549,2190	15497,6221	14212,0476	1285,5745	0,0000	1041,8992	295,2722
ETHANE		2600,0088	2570,5642	1796,6187	773,9455	39,6990	348,1002	455,2898
PROPANE		3712,2470	3615,8181	1587,4002	2028,4179	5828,7265	507,8560	1616,9908
ISOBUTANE		1066,3223	1014,8169	262,4924	752,3245	134,8500	112,7673	691,0626
n-BUTANE		1178,5612	1108,5416	232,8631	875,6785	27,3294	111,1722	834,5259
ISOPENTANE		535,1861	480,3405	53,4885	426,8520	0,0000	32,7388	448,9588
n-PENTANE		368,8000	326,4461	32,4969	293,9492	0,0000	20,6876	315,6155
n-HEXANE		441,5660	330,7326	10,3296	320,4030	0,0000	9,4490	421,7874
n-HEPTANE		839,8722	499,1964	6,3715	492,8249	0,0000	7,5636	825,9371
Total flowrate	lb/h	26297,7786	25450,0659	18199,9057	7250,1602	6030,6050	2192,4294	5905,4435
Mass fractions								
NITROGEN		0,0002	0,0002	0,0003	0,0000	0,0000	0,0001	0,0000
METHANE		0,5913	0,6089	0,7809	0,1773	0,0000	0,4752	0,0500
ETHANE		0,0989	0,1010	0,0987	0,1067	0,0066	0,1588	0,0771
PROPANE		0,1412	0,1421	0,0872	0,2798	0,9665	0,2316	0,2738
ISOBUTANE		0,0405	0,0399	0,0144	0,1038	0,0224	0,0514	0,1170
n-BUTANE		0,0448	0,0436	0,0128	0,1208	0,0045	0,0507	0,1413
ISOPENTANE		0,0204	0,0189	0,0029	0,0589	0,0000	0,0149	0,0760
n-PENTANE		0,0140	0,0128	0,0018	0,0405	0,0000	0,0094	0,0534
n-HEXANE		0,0168	0,0130	0,0006	0,0442	0,0000	0,0043	0,0714
n-HEPTANE		0,0319	0,0196	0,0004	0,0680	0,0000	0,0034	0,1399
Physical state		Liq./Vap.	Vapor	Vapor	Liq./Vap.	Liq./Vap.	Vapor	Liquid
Temperature	°F	114,9994	112,9994	94,6596	93,5467	-8,5950	93,5466	185,9031
Pressure	psi	832,9998	832,9998	832,9998	832,9998	31,0000	832,9998	832,9998
Enthalpy	Btu/h	-449992,4455	-380826,1655	-383353,0502	-816587,9766	-281235,4795	-71422,6031	-448957,5698
Vapor fraction		0,9893	1,0000	1,0000	0,3524	0,9335	1,0000	0,0000

2.3. Profile of temperature of reference sheet in the E101 exchanger

Temperature profiles in the heat exchanger are available after the simulation from the exchanger configuration window (profile tab). A double-click on the selected profile generate the graph.

E101 - Temperature profile of the reference sheet

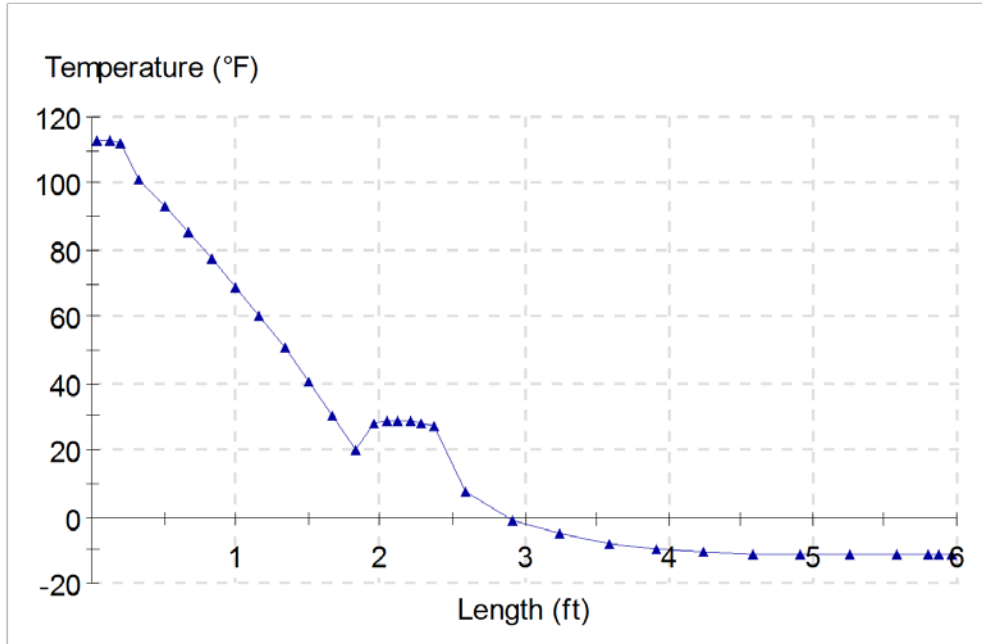

Temperature profile of the reference sheet

2.4. Column C101 composition profiles

Composition profiles can be accessed after the simulation in each column configuration window, in the “Profiles” tab. Double clicking on the profile will generate the corresponding graph.

It is important to note that, in ProSimPlus, first stage correspond to condenser and last stage to reboiler (numbering from top to bottom).

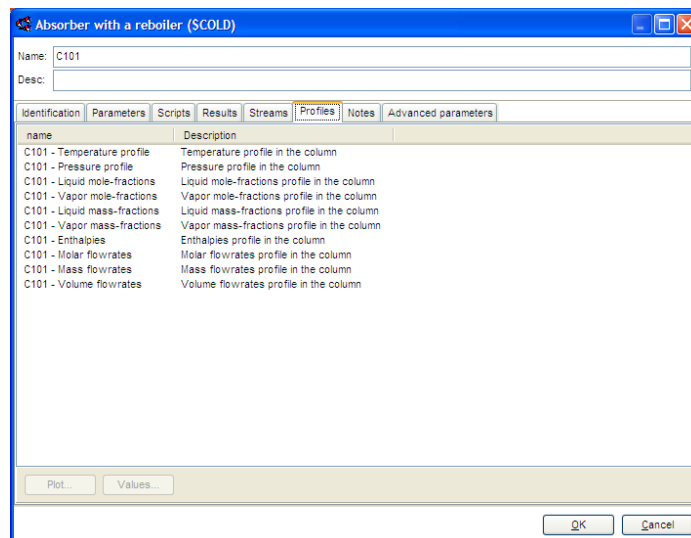

C101 temperature profile

C101 - Temperature profile

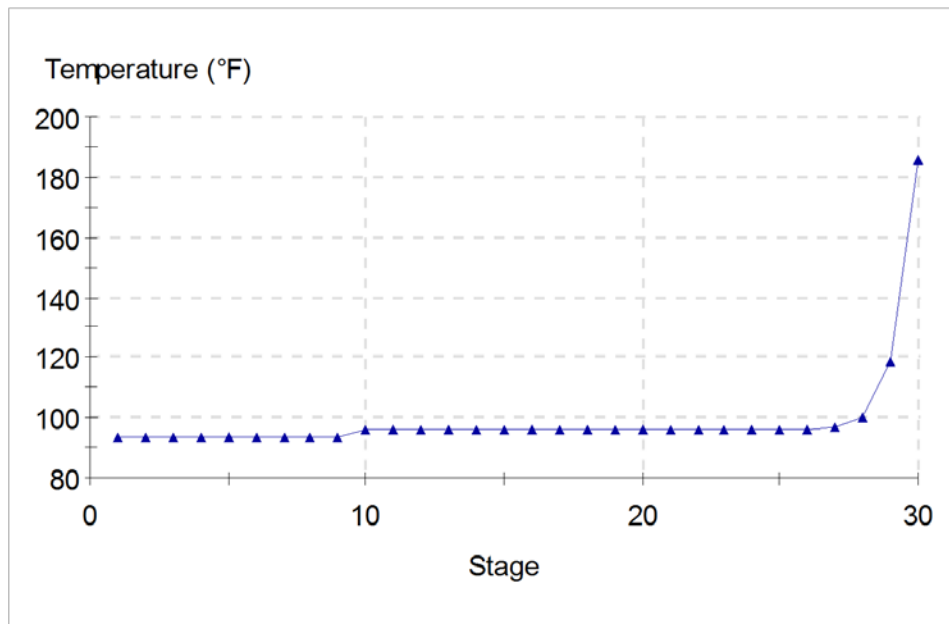

Temperature profile in the column

C101 liquid mass-fraction

C101 - Liquid mass-fractions

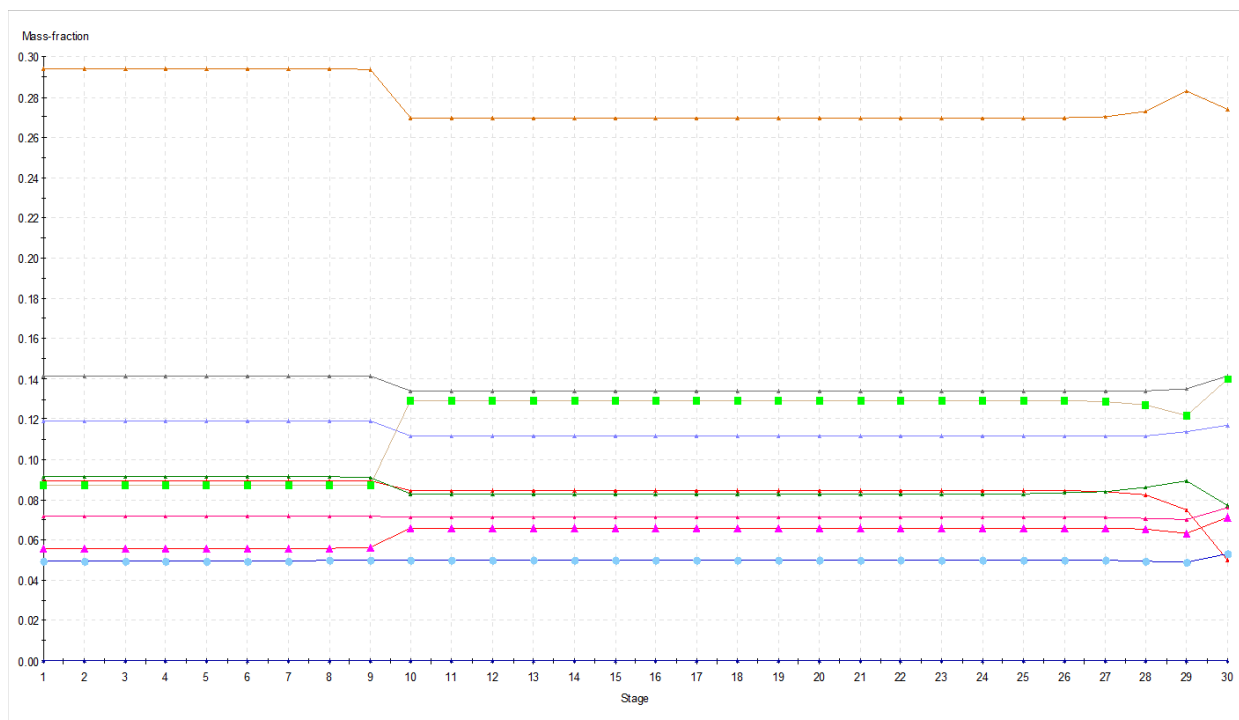

—●— NITROGEN —●— METHANE —●— ETHANE —●— PROPANE —●— ISOBUTANE
—●— n-BUTANE —●— ISOFENTANE —●— n-PENTANE —●— n-HEXANE —●— n-HEPTANE

Liquid mass-fractions profile in the column

3. REFERENCES

- [1] Polasek J.C., Donnelly S.T., Bullin J.A.
"Process Simulation and Optimization of Cryogenic Operations Using Multi-Stream Brazed Aluminium Exchangers"
Proceedings of the Sixty-Eighth GPA Annual Convention
Tulsa, OK : Gas Processors Association, 1989 : 100-106
- [2] Peng Y.D., Robinson D.B.
"A new two constant equation of state"
I.E.C. Fundam., 15, 1, 59-64 (1976)